

1ST YEAR SUBJECT CHOICE



Ailish Egan
Guidance Counsellor

FACTORS INFLUENCING SUBJECT CHOICE

- **Interest** in the subject – will tend to work harder in areas of interest
- **Ability/Aptitude** in the subject
- Is the subject **necessary** for your chosen career?
- Is the subject **desirable** for your chosen career?



SENIOR CYCLE OPTIONS



Students have a choice of Senior Cycle Options:

- Optional **Transition Year**
- **Traditional Leaving Certificate** – two year academic programme with options for further study in University, IT's and Post Leaving Cert colleges
- **Leaving Certificate Applied (LCA)** – two year practical programme with options for further study in Post Leaving Cert Colleges, Training Colleges, FÁS, or direct employment

CORE SUBJECTS

ALL STUDENTS WILL CONTINUE TO STUDY THE FOLLOWING SUBJECTS FOR JUNIOR CYCLE

- English
- Irish
- Maths
- History
- Geography
- Science
- Religion
- CSPE
- SPHE
- PE

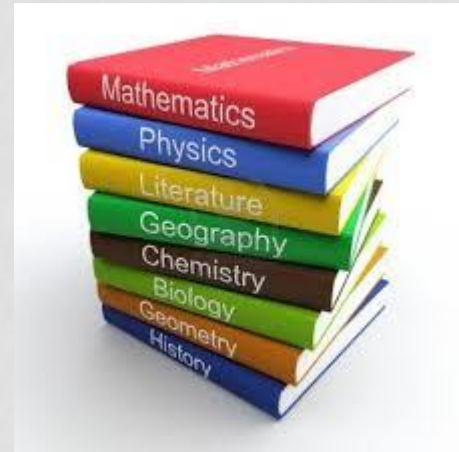

Students are also expected to study a continental language. They can choose from **French** or **German**.

CHOICE SUBJECTS

STUDENTS WILL CHOOSE AN ADDITIONAL 3
SUBJECTS FROM THE FOLLOWING LIST

- Home Economics
- Art
- Music
- Business Studies
- Technical Graphics
- Woodwork
- Metal work
- Information Technology



- Higher level English is necessary for
 - Media Studies, Journalism, English Studies.
- Useful for
 - Law, Speech & Language Therapy, Politics, Public Relations, Applying to UK colleges.

IRISH

Higher Level Irish is necessary for

- Primary Teaching
- Any other degree where Irish language is studied e.g. Commerce with Irish

Ordinary Level Irish is required for

- Cadets, Gardaí, Public Sector
- Irish is also useful for Law, Secondary Teaching.





CONTINENTAL LANGUAGE FRENCH, GERMAN



- A continental language is necessary for entry to most university programmes.
- Higher Level is required for courses with a language such as French through Arts, Commerce with Spanish, Law with German, European Studies,
- Students can take languages like Italian, Spanish, Chinese and Japanese at beginners level in College but usually need to have Higher Level in another language.

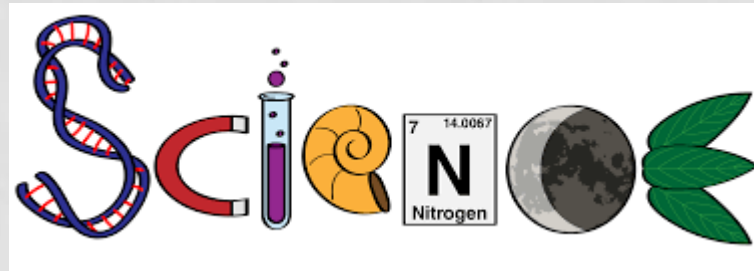

- Breaks into 4 subjects at Leaving Certificate – Biology, Chemistry, Physics and agricultural science.
- Science is necessary for Medicine, Dentistry, Veterinary Medicine, Pharmacy, Engineering, Science Degree, Speech & Language Therapy, Physiotherapy, Occupational Therapy, Optometry, Radiotherapy, Dietetics, Nursing, Beauty Therapy, Complementary Therapy.

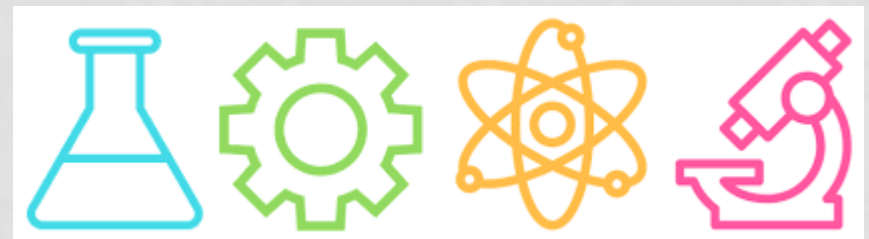
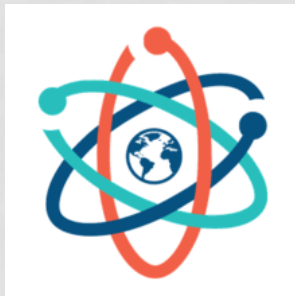

HOME ECONOMICS

- At JC level students learn about Biology, Health and Nutrition, Food Preparation and Cookery, Managing Money, Home and Consumer rights, and Textiles and Craft.
- 50% exam in June and 50% cooking practical
- Be careful of gender bias – it is useful & practical for all.
- An interest in home management, cooking and crafts, biology and sociology.



HOME ECONOMICS

- Can be used for Home Economics Teaching
- Useful for careers in culinary arts, tourist industry, childcare, social sciences, fashion and social care / work careers.





- Not specifically required for most art courses, but students must submit a portfolio of work for entry to Art College – Art in school will help to build the portfolio
- Art is also desirable for Architecture, teaching, advertising, graphic design, animation, teaching, film, product design, etc.



ART

- Practical project - No written exam in June
- Students learn a variety of skills – drawing, painting, sculpture, printmaking, etc
- An aptitude is needed.
- It is important that it is not taken as an easy subject
- Continuous work needed for year long project
- Good for creative outlet and wellbeing.
- At LC level 38% for Art History and 62% for practical including 10 week project and life drawing exam.





- Not specifically required for entry to music courses but students must sit a music entrance exam for which the Music course provides an excellent foundation.
- Music is also a valuable subject for becoming a professional musician, sound engineering, multimedia, entertainment, teaching, speech therapy and other jobs within the music industry outside of performance plus for enjoyment.

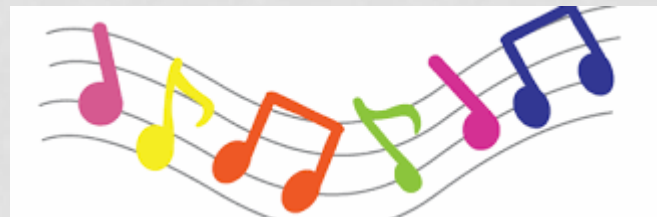



- Aptitude is needed included the ability to learn and read music.
- Need to be interested.
- For JC 30% is practical
- For LC it is necessary to have JC music standard
- For LC 50% is practical and includes using software



BUSINESS STUDIES



- Business breaks into 2 subjects at Leaving Certificate level – Business Studies and Accounting.
- Business Studies is not essential for entry to business based courses but provides an excellent base for future study in the Business Area.
- Useful for Accounting, Marketing, Human Resources, Economics, Banking, Insurance.

BUSINESS STUDIES

- JC Business in an advantage for Accounting and Business
- Learn about world of work & business
- Communication skills / report writing etc
- Learn how to collect / organise / record data
- Basic accounting
- Rights & responsibilities in the workplace
- Calculating wages / benefits of saving
- Membership of the EU.

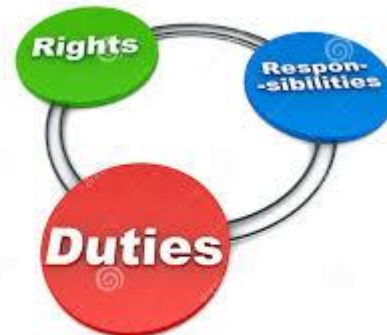

TECHNICAL GRAPHICS

- Not necessarily required for any courses but can be useful
- Good for construction, graphic design, architecture, general design and engineering careers plus architectural design.

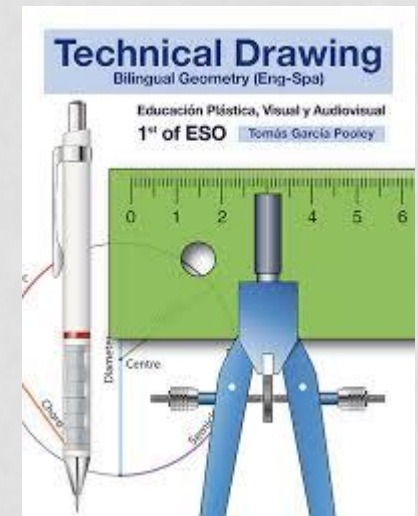
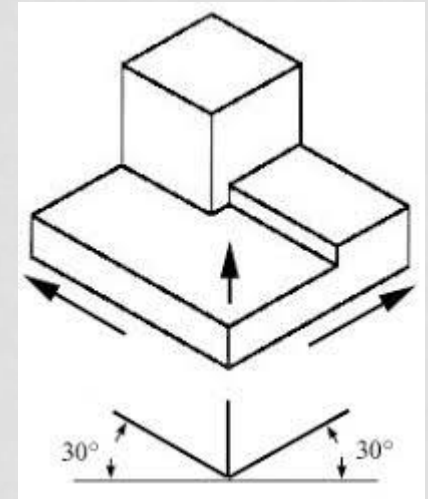



WOODWORK



- LEARN THE SKILLS REQUIRED TO USE TOOLS AND EQUIPMENT TO DESIGN AND PRODUCE WOOD PRODUCTS. STUDENTS ALSO LEARN ABOUT WOOD AS A MATERIAL AND HOW IT IS PRODUCED.
- 70% PROJECT IN JC.
- PRACTICAL APTITUDE IS NEEDED.
- FOR LC (CONSTRUCTION STUDIES) IT IS AN ADVANTAGE TO HAVE IT STUDIED TO JC LEVEL.
- AT LC 25% GIVEN FOR A PROJECT, 25% GIVEN FOR A 4 HR PRACTICAL, AND 50% GIVEN FOR AN EXAM COMPRISING OF WRITING AND DRAWING.

WOODWORK

- USEFUL FOR CAREERS IN CARPENTRY, ENGINEERING, QUANTITY SURVEYING, CONSTRUCTION, ARCHITECTURE, ARCHITECTURAL TECHNOLOGY AND TRADES.





METALWORK



- At JC level students learn how to use a wide variety of tools and machines to shape, cut and join metal materials. They learn how to read and follow technical drawings correctly while also learning about the properties of different metals.
- 75% practical for JC.
- Aptitude is needed.
- At LC Metalwork is called Engineering and it is highly recommended to have completed JC metalwork.
- 50% is given for practical and 50% for exam in June.

METALWORK

- Useful for careers in engineering, plastics and all technically related careers
- Useful for careers in engineering, mechanics, apprenticeships, industrial design and all technology related careers.





IT



- 2017/2018 KCS was one of twenty schools in Ireland to pilot the new computer studies short course which combines **Coding** and **Digital Media Literacy**
- **Classes:** 1 x double class of Coding and 1 x double class of Digital Media Literacy in Y2 and Y3
- **Assessment:** Classroom Based Assessments (CBA's) / collection of work over Y2 and Y3 and final project in Y3

JC SHORT COURSES

- 2017/2018 KCS was one of twenty schools in Ireland to pilot the new computer studies short course which combines **Coding** and **Digital Media Literacy**
- **Classes:** 1 x double class of Coding and 1 x double class of Digital Media Literacy in Y2 and Y3
- **Assessment:** Classroom Based Assessments (CBA's) / collection of work over Y2 and Y3 and final project in Y3

JC ICT SHORT COURSE

Coding

- The short course aims to develop the student's ability to formulate problems logically; to design, write and test code through the development of programs, apps, games, animations or websites; and, through their chosen learning activities, to learn about computer science.

Digital Media Literacy

- This short course aims to extend and refine students' ability to use digital technology, communication tools, and the internet creatively, critically and safely, in support of their development, learning and capacity to participate effectively in social and community life.

STUDENTS WHO CHOOSE THIS SUBJECT SHOULD:

- Have an interest in:
 - Coding
 - A future career in IT
 - Being creative
 - Learning new applications

- Students should have the ability to:
 - Problem solve

- An interest in gaming is not a sufficient reason for choosing this subject

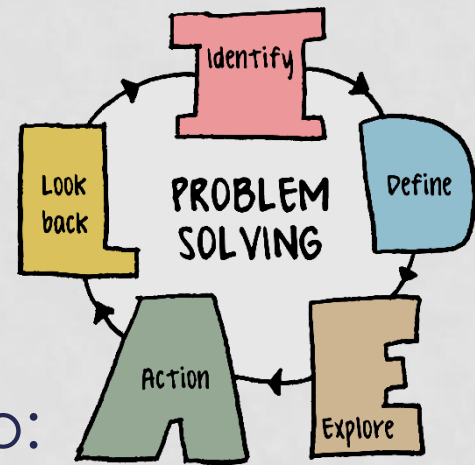

MORE INFORMATION

- Coding:
 - <https://www.curriculumonline.ie/Junior-cycle/Short-Courses/Coding>
- Digital Media Literacy
 - <https://www.curriculumonline.ie/Junior-cycle/Short-Courses/Digital-Media-Literacy>

SO, WHAT HAPPENS NOW?

- Forms to be handed into **Mr. Hogan's office** on H Block by **February 7th at 1pm.**
- Organised into groups taking clashes into account.
- Once finalised groups a letter will be sent home.

THANK YOU FOR YOUR ATTENTION

